



Established 1930

Distributors of new & used workshop Equipment

P143 20 TON

HYDRAULIC FLOOR PRESS

PARTS LIST

21-08-2002

P143 21.8.2002

20 TON HYDRAULIC FLOOR PRESS

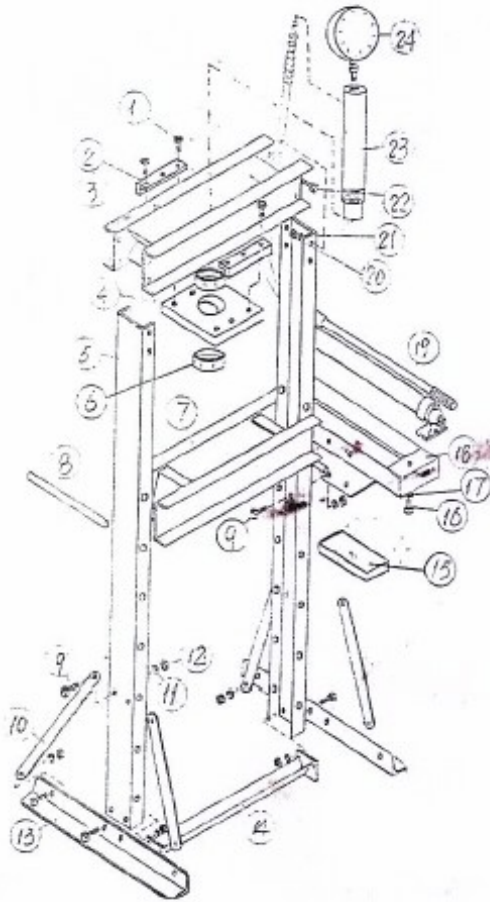

Parts No	Description	Q'ty
1	Bolt M8x35	6
2	Ram Pressure Plate	2
3	Crossbeam	1
4	Fixed Plate	1
5	Upright Post	2
6	Round Nut	2
7	Press Platform	1
8	Red	2
9	Bolt M8x30	16
10	Support	4
11	Lock Washer Ø8	22
12	Nut M8	16
13	Angle Steel	2
14	Spreader	1
15	Pad Plate	2
16	Bolt M10x25	3
17	Lock Washer Ø10	3
18	Ram Base	1
19	Pump	1
20	Nut M16	8
21	Lock Washer Ø16	8
22	Bolt M16x30	8
23	Ram	1
24	Pressure Gauge	1

A NOTE ON SAFETY

We've done all we can to assure this press offers the utmost in safety, but you have to do your part. No amount of warning can take the place of your good judgment, so make sure it's the first thing you bring to any job.

Beyond that here are some obvious tips:

- Steel and other materials can shatter, so always use protective eyewear that complies with the appropriate ANSI code.
- If you detect anything that may indicate imminent structural failure, stop using the press immediately and inspect it thoroughly.
- Bolt the press to the floor if it is to be used on bulky or unstable items.
- Do not use press to compress springs or any other item that could disengage and cause a potential hazard.